

Eargasmic: The Wow Factor for Your Listeners and Viewers!!

The Birth of Deja Vu!!

Frank Foti
The Telos Alliance
Cleveland, Ohio

Innovation Never Sleeps!

“

Be curious about all fields; the future belongs to those who can connect creativity to technology.

”

WALTER ISAACSON
WRITER

Forbes

Innovation Never Sleeps!

Wouldn't it be a blast if you could hear your favorite music all over again for the first time?

Innovation Never Sleeps!

How all this came about!

Steve and Frank scheming cool tech for HD Radio...

Oh, another one of Frank's stories!! 😊

Innovation Never Sleeps!

Déjà Vu processes stereo audio and renders it into discreet, 5.1 surround sound that has music creators and artists overjoyed. No tricks, no phasing, no reverb, nada.

Innovation Never Sleeps!

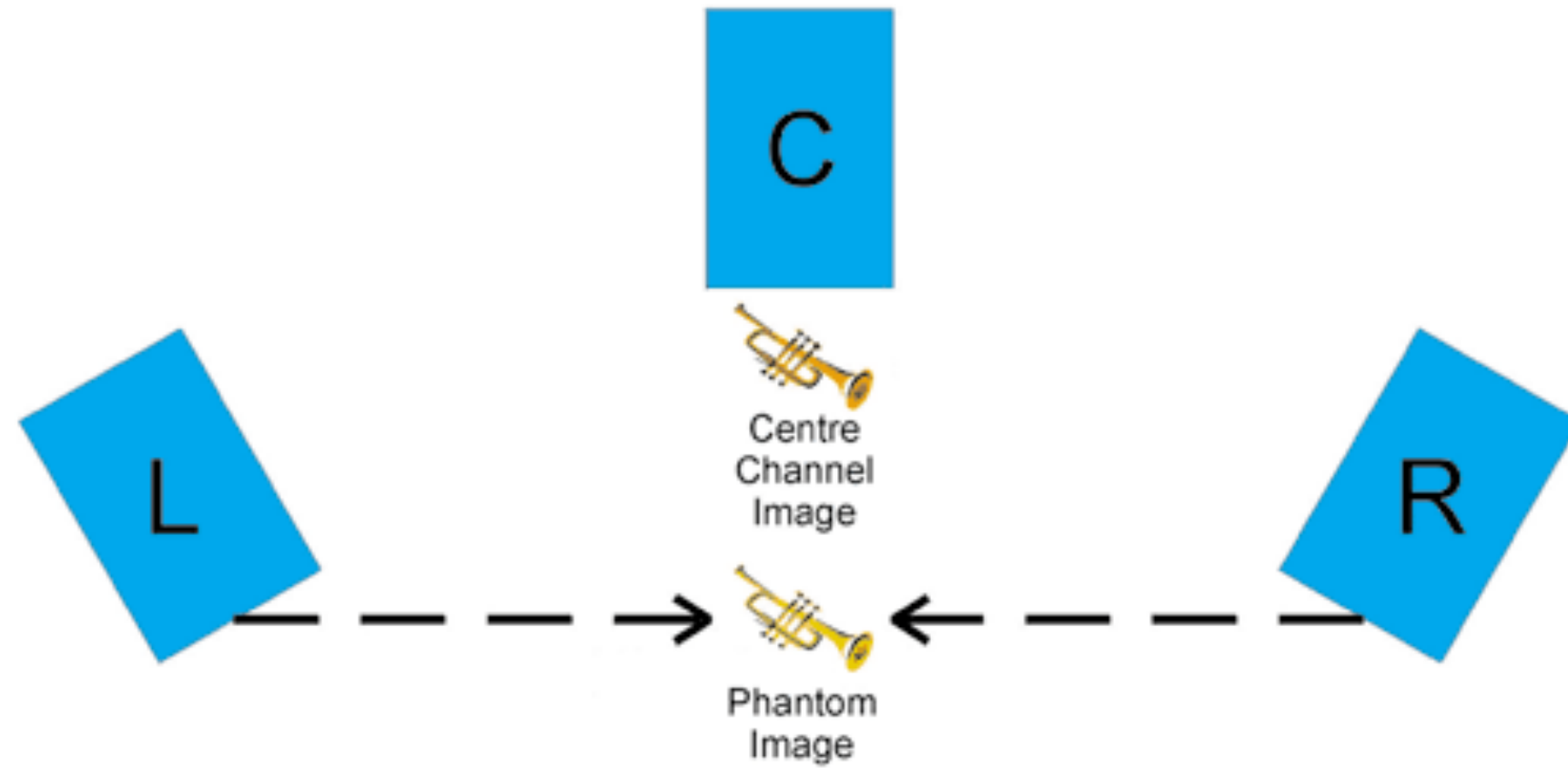

Innovation Never Sleeps!



Innovation Never Sleeps!

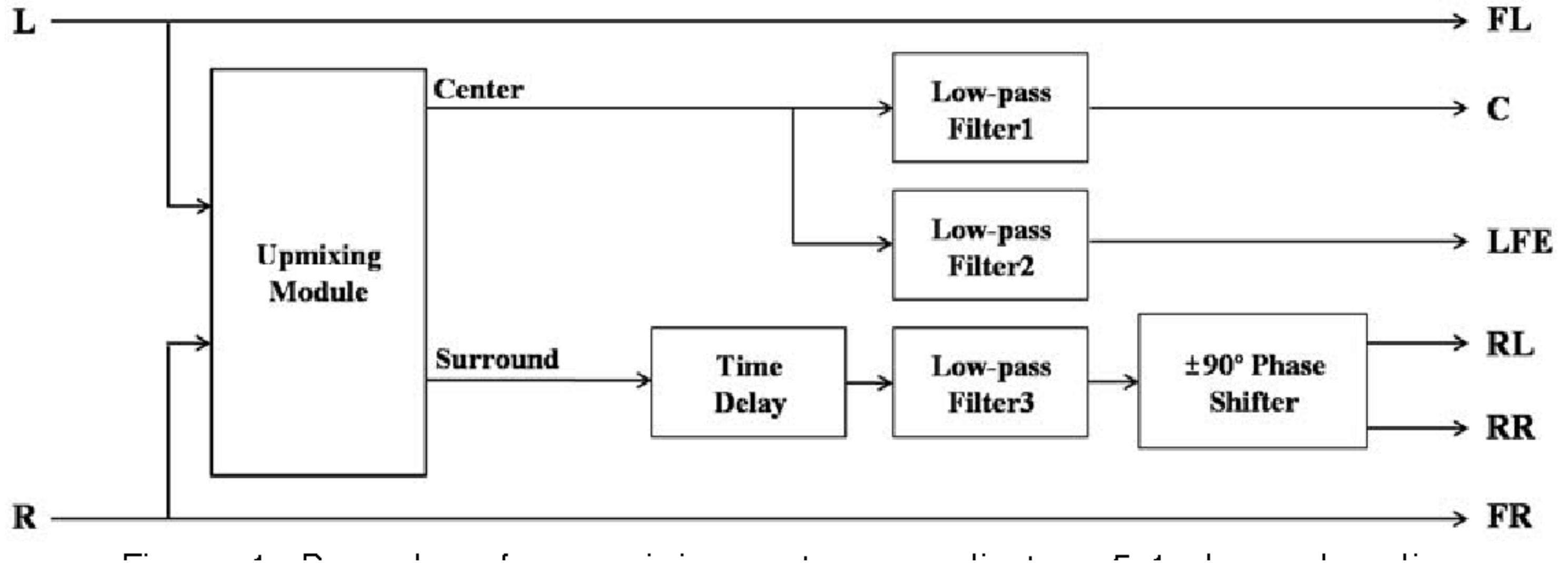

Innovation Never Sleeps!

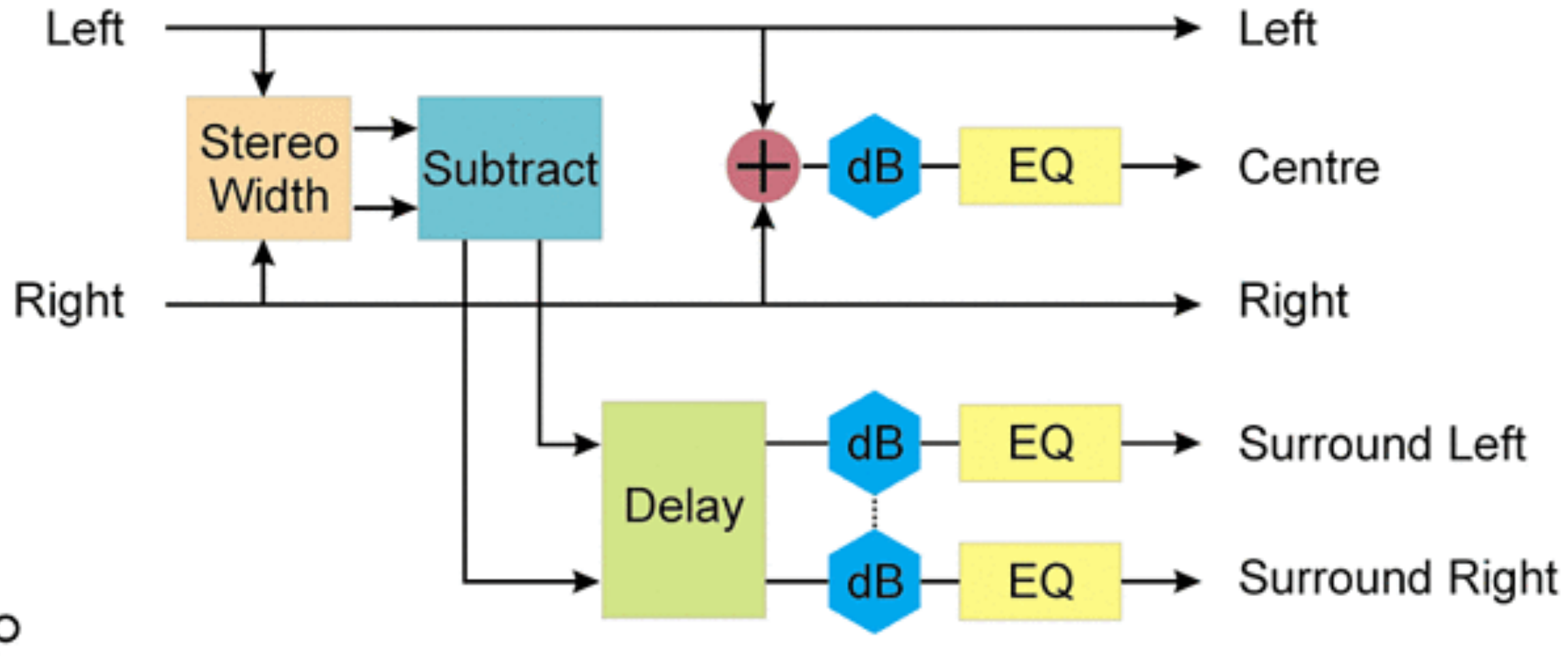

Innovation Never Sleeps!

Here's how Déjà Vu is different:

- Faithful to the music's original production characteristics
- Does not use perceptual tricks to create surround sound
- Artifact-free
- Consistent surround sound representation
- Does not degrade overall audio performance
- Sounds like it was originally mixed in 5.1

Innovation Never Sleeps!

What is our Déjà Vu surround sound technology?

It is based on our audio algorithm which renders immersive audio from the original stereo mix. We use a linear process, which preserves natural sonic integrity, frequency response, audio level, and faithfully supports all the original production characteristics.

It's all dependent on the center channel!!

Innovation Never Sleeps!

No tricks up our sleeve.

Our Déjà Vu technology does not employ any synthesized channel steering, phase modification, reverb, dynamic level adjustment, or time delay as mechanisms to create surround.

All of those generate artifacts, inconsistent surround representation, do not naturally support the mix, and usually degrades the overall audio performance.

Innovation Never Sleeps!

What makes Déjà Vu better than other technologies out there?

Déjà Vu can isolate all the spatial sonic cues in stereo audio, then place these cues (segments) into the appropriate location of the surround field. This is done without any unnatural artifacts.

The result is an experience that appears rich, musical, natural, and as if the performance is occurring all around the listener.

Innovation Never Sleeps!

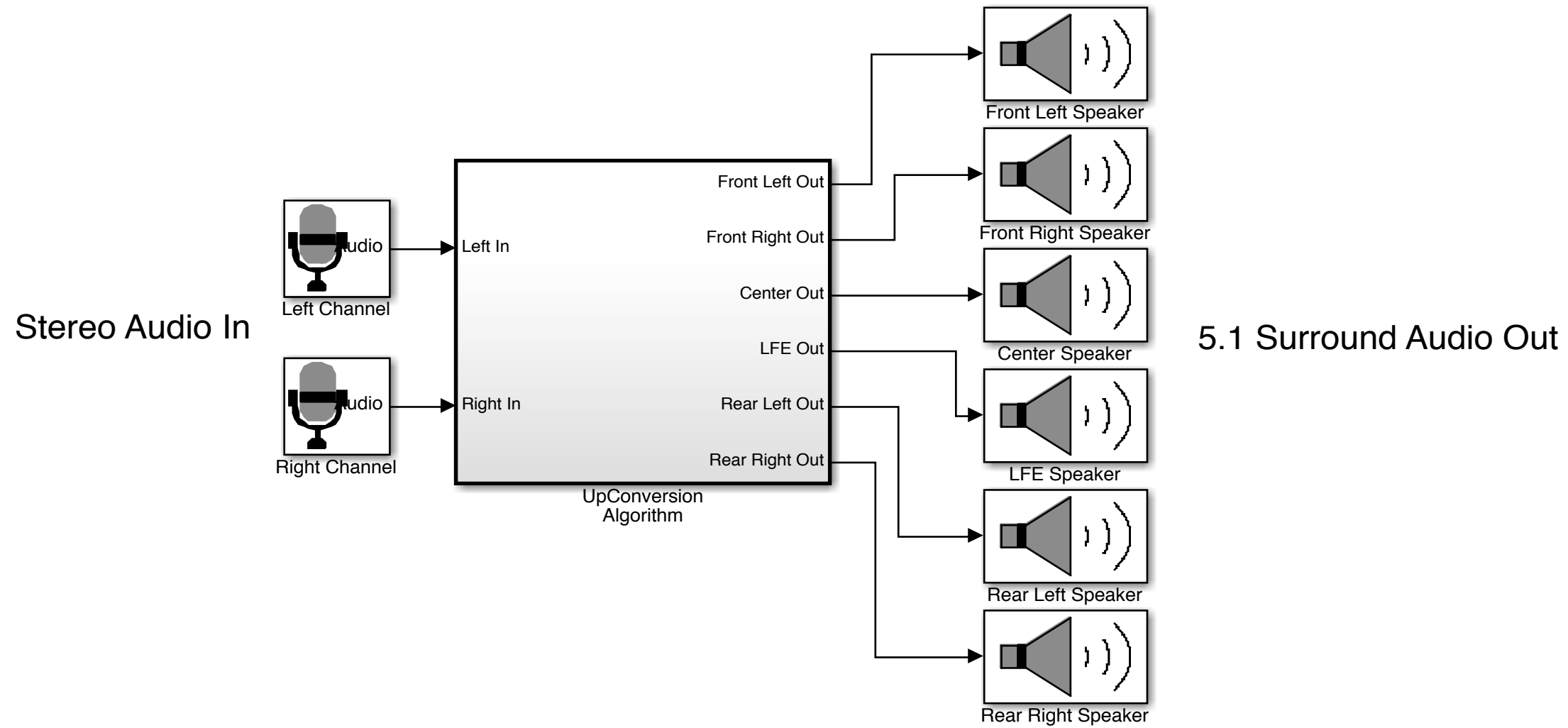

Innovation Never Sleeps!



Innovation Never Sleeps!

Among the list of accomplished industry influencers include:

- Gary Katz (Produced Steely Dan, Donald Fagan, Laura Nyro, Diana Ross, Joe Cocker)
- Jean-Michel Jarre - French composer, performer and producer who has sold an estimated 80 million records
- Grammy-Award Winner Hugh Padgham (The Police, Sting, Phil Collins, XTC & 10cc)
- Grammy-Award Winner Frank Filipetti (Wicked, Elton John, Foreigner, Luciano Pavoroti, Tim Rice, Carly Simon, James Taylor)
- Kirk Yano, Producer, (Public Enemy, Mariah Carey, Miles Davis, Phoebe Snow)

Innovation Never Sleeps!

- Déjà Vu for Radio & Streaming
- Déjà Vu for TV
- Déjà Vu for the car
- Déjà Vu for Music Creator
- Déjà Vu for Live Venues
- Déjà Vu for OEM Partners
- Déjà Vu for Home

Innovation Never Sleeps!

Now, let's have some fun, and have a listen....

Innovation Never Sleeps!



THANK YOU!!!



1241 Superior Avenue Cleveland, OH 44114 USA | +1.216.241.7225 | TelosAlliance.com

